



HORIZONTAL MACHINING CENTER

HK-LH series

HEAKE MACHINERY CO., LTD.

Taiwan Head Office:

No. 44-8, Shuimen Rd., Houli Dist., Taichung City 421017, Taiwan

TEL: +886-4-2557-8080 FAX: +886-4-2557-9090

E-mail: sales@heake.com.tw

www.heake.com.tw



Web



FB



HEAKE LH SERIES

HORIZONTAL MACHINING CENTER

HK-LH630(A)

- Table sizes 630 x 630mm
- X, Y, Z-axis travel 1000 x 9000 x 10000mm
- Rapid traverse rates on X, Y, Z-axis 40m/min
- Traveling column
- Twin swing type automatic pallet change (optional)
- B-axis indexing degree 0.001° (1° optional)
- Fully enclosed splash guard
- Max. table load 650kg (single pallet)

HK-LH800(A)

- Table sizes 800 x 800mm
- X, Y, Z-axis travel 1500 x 1100 x 1100mm
- Rapid traverse rates on X, Y, Z-axis 24/30m/min
- Traveling column
- Twin swing type automatic pallet change (optional)
- B-axis indexing degree 0.001° (1° optional)
- Fully enclosed splash guard
- Max. table load 2200kg (single pallet)

HK-LH1000(A)

- Table sizes 1000 x 1000mm
- X, Y, Z-axis travel 1500 x 1100 x 1100mm
- Rapid traverse rates on X, Y, Z-axis 24/30m/min
- Traveling column
- Twin swing type automatic pallet change (optional)
- B-axis indexing degree 0.001° (1° optional)
- Fully enclosed splash guard
- Max. table load 2200kg (single pallet)

A Combination of High Performance Machine and Intelligent Control

The Heake Horizontal Machining Center features a highly rigid machine structure, enabling it to present exceptional machining stability and accuracy, especially in high speed machining. Three axes are mounted with linear guideways, traveling column design, and automatic pallet change to provide a dramatic increase in machining efficiency. The HK-LH series is equipped with a Fanuc controller in combination with the use of Heake self-developed software functions, making machine operation and management more convenient.



▲ HK-LH800A
WITH TWIN PALLETS

OPTIMIZED STRUCTURE DESIGN

A Perfect presentation of Structural Rigidity and Dynamic Stability

- Box type structure design combined with internal ribbing to achieve outstanding rigidity and deformation free performance.
- One-piece fabricated base provides a solid support for the entire machine.
- Traveling column structure effectively enhances operation efficiency.
- Linear guideways are deployed on the step structure of X-axis for higher cutting stability.
- X, Y, Z-axes are all mounted with roller type linear guideways with outstanding heavy loading capacity.
- The vertical movement (Y-axis) of the spindle head is counterbalanced by double air cylinders, leading to fast travel, as well as stable and smooth vertical movement.
- Chip augers are equipped at both sides of the base, allowing for the removal of chips immediately during machining.



TWIN CHIP AUGERS

- There is one each of chip auger mounted at the right and left side of the base, which can deliver chips generated during cutting to the chip conveyor at the back side of the machine.
- The chip augers can prevent thermal effects that occur due to chip accumulation and keep the machine interior clean at all times.

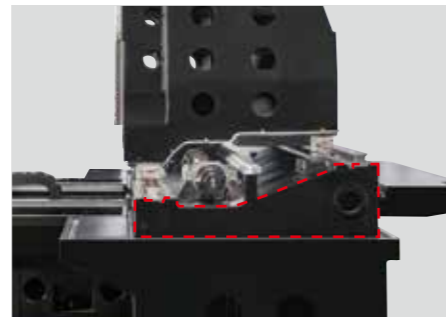

MACHINE STRUCTURE OF HK-LH-800(A)

The massive base and robust column combined with internal ribbing ensure lifetime deformation free performance, while exhibiting outstanding rigidity and stability.



※ EXTRA LARGE SPAN

A ROLLER TYPE LINEAR WAYS ON THREE AXES

The X, Y, and Z-axes are all mounted with heavy-duty linear ways, with a great span between the ways, resulting in high rigidity, low friction coefficient, and outstanding dampening capability.

B HIGHLY RIGID COLUMN

The column is a box type double wall structure, preventing deformation even after years of use.

C TRAVELING COLUMN

The column moves smoothly and helps to increase the operation efficiency of the machine.

D ONE-PIECE FABRICATED BASE

The H-shaped base is one-piece fabricated, providing solid support for the entire machine.

E STEP LAYOUT OF LINEAR WAYS

The column moves on linear guideways with step layout, enhancing cutting stability.

F DOUBLE AIR CYLINDERS COUNTERBALANCE ON Y-AXIS

Y-axis vertical movement is counterbalanced by the use of two air cylinders with fast response on axial direction change. Thus, smooth and stable vertical movement can be achieved.

MODEL	HK-LH630(A)	HK-LH800(A)	HK-LH1000(A)
X	850	900	900
Y	725	750	750
Z	720	900	900

Unit: mm

AUTOMATIC PALLET CHANGE (APC) FAST, STABLE, HIGH PRECISION POSITIONING



SWING TYPE AUTOMATIC PALLET CHANGE

- The swing type pallet change dramatically saves machine step time for loading and unloading workpieces.
- Pallet change motions are fast and smooth.
- Pallet swing speed can be adjusted according to load requirements (Servo APC only)

HIGH ACCURACY OF PALLET POSITIONING

- A servomotor in combination with the use of 4 tapered cones, ensuring high positioning accuracy, drives the pallet rotation.
- B-axis indexing accuracy is 0.001°.
- B-axis can also be indexed through gear with 1° of indexing accuracy. The gear disk is matched by hydraulic power featuring high repeatability.

MAX. WORKPIECE SIZES

Unit: mm

	HK-LH630(A)	HK-LH800(A)	HK-LH1000(A)
A	Ø1100	Ø1600	Ø1650
B	1250H	1450H	1400H

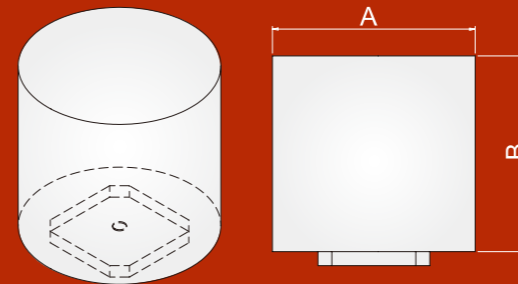

TABLE: 0.001°

• TWO-SECTION WORM / WORM GEAR SET

- * The specially designed tooth shape features double contacting teeth number than that of traditional designs, and the contact area is five times more. As such, the force exerted on the unit area of tooth flank on a worm gear is only 1/5 of the average value, which means less wear.
- * The worm shaft is designed with two sections. Backlash adjustment is made conveniently by simply turning the single side of the worm shaft. Normal backlash is adjusted to 5~7μ.
- * Low pressure angle design is much smaller than the 12°~15° design of double load, so that the motor output torque can be fully applied in the rotating torque direction. This feature is suitable for synchronized continuous milling operations.

• SPINDLE BEARING

The table is equipped with large embedded type axial radial bearings, which can withstand the loads in horizontal and vertical directions. In addition, it can also enable the disk to rotate smoothly and accurately for a long time.

• BRAKE SYSTEM

The table employs full circumference brake with axial clamping. As the clamping surface is the axial area of the spindle, the center point is not offset, and it can avoid deformation on the disk and variations in accuracy. Thus, high rigidity and heavy cutting resistance can be achieved. General circumference braking may cause the table center to offset. As the force exerted is in the radial direction, table center offset may occur.

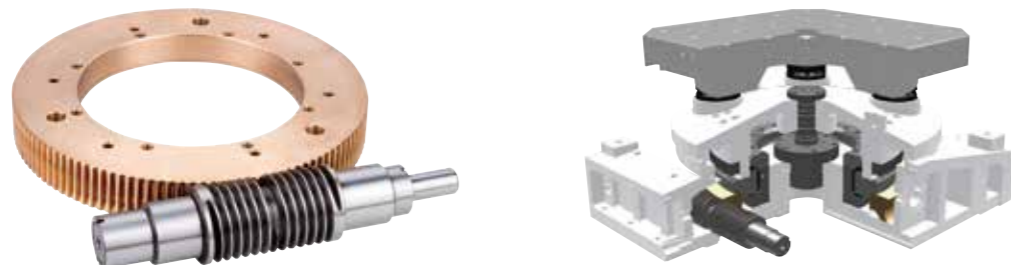
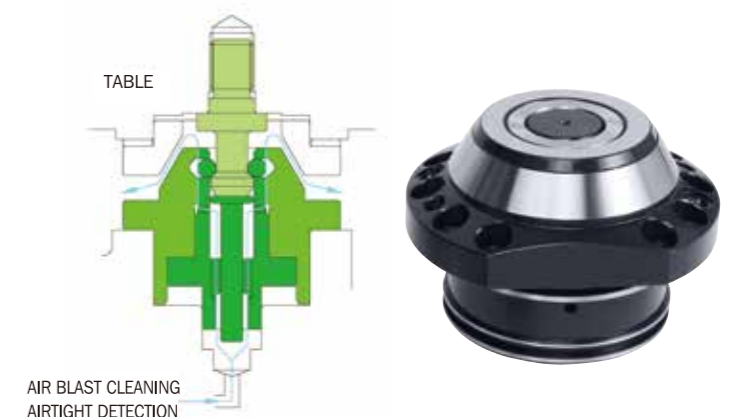

TABLE: 1°

- The table employs a special clutch gear for positioning. Mechanical positioning accuracy can reach ±3 arc-sec. It can maintain high accuracy and high stability even after long-term use.
- The contact area of the positioning teeth is maximized to achieve stable accuracy, high rigidity, and heavy cutting resistance.
- The table interior is designed with moisture-proof structure that effectively prevents cutting fluid and chips from entering the body of the rotary table.

FEATURES OF TAPERED CONE AND SLEEVE

- The table is designed with 4 tapered cone holding mechanism. With features of fast positioning, high accuracy, and extra powerful holding force, table stability and positioning accuracy can be assured. A powerful air blow system blasts air through the tapered cones for cleaning chips. The airtight detection on the tapered cone ensures table holding stability and positioning accuracy.
- The tapered cone is an enclosed design instead of the conventional open type design. This ensures that cutting fluid and chips do not enter the sleeve during pallet change, while ensuring holding force and accuracy for a long time.



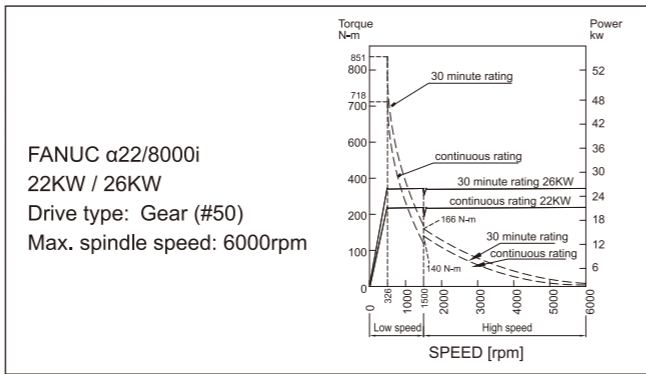
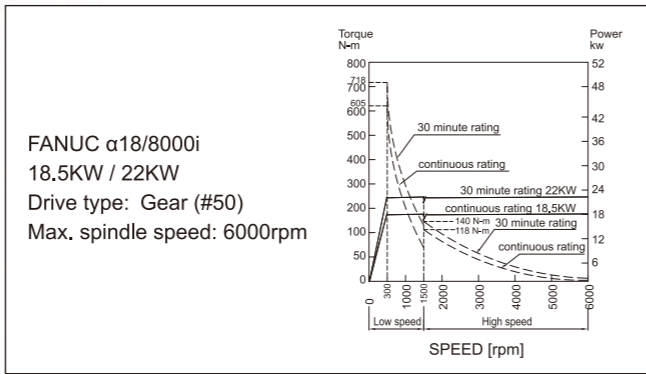
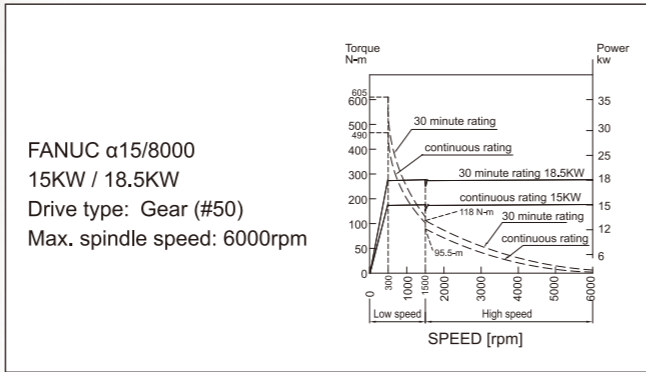

HIGH PRECISION SPINDLE

- The long nose spindle design makes the cutting tool easy to access the workpiece, effectively preventing spindle chatter during machining.
- Spindle nose taper: BBT-50

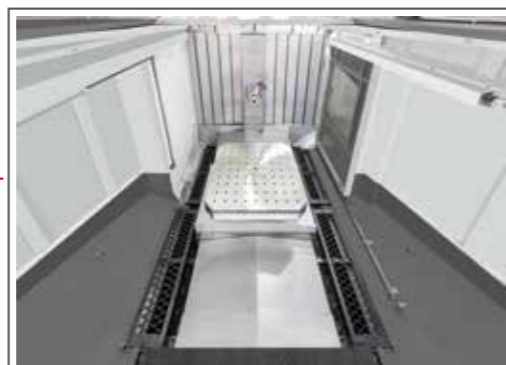

◀ **FIXED TYPE TABLE**
HK-LH-800 with single pallet

LARGE MACHINING CAPACITY * Mineral: S45C



FACE MILLING

- | | |
|--------------------------------------------------------------------------------------------------------------------------------------------------------------------------------------------------------------------------------------------------------------------------------------------------------------|----------------------------------------------------------------------------------------------------------------------------------------------------------------------------------------------------------------------------------------------------------------------------------------------------------------|
| <ul style="list-style-type: none"> ■ Motor: 22/26kw / 4000rpm ■ Tool diameter: Ø160 mm ■ Speed: 290 rpm ■ Feed rate: 1150 mm/min ■ Cutting depth: 5 mm ■ Cutting width: 140 mm ■ Material removal rate: 805 cc/min ■ Load: 90% | <ul style="list-style-type: none"> ■ Motor: 22/26kw / 6000rpm ■ Tool diameter: Ø160 mm ■ Speed: 330 rpm ■ Feed rate: 1080 mm/min ■ Cutting depth: 4.5 mm ■ Cutting width: 140 mm ■ Material removal rate: 680 cc/min ■ Load: 97% |
|--------------------------------------------------------------------------------------------------------------------------------------------------------------------------------------------------------------------------------------------------------------------------------------------------------------|----------------------------------------------------------------------------------------------------------------------------------------------------------------------------------------------------------------------------------------------------------------------------------------------------------------|



END MILLING

- | | |
|----------------------------------------------------------------------------------------------------------------------------------------------------------------------------------------------------------------------------------------------------------------------------------|----------------------------------------------------------------------------------------------------------------------------------------------------------------------------------------------------------------------------------------------------------------------------------|
| <ul style="list-style-type: none"> ■ Motor: 22/26kw / 4000rpm ■ End mill: Ø40 mm ■ Speed: 410 rpm ■ Feed rate: 355 mm/min ■ Cutting depth: 30 mm ■ Cutting width: 12 mm ■ Material removal rate: 127 cc/min | <ul style="list-style-type: none"> ■ Motor: 22/26kw / 6000rpm ■ End mill: Ø40 mm ■ Speed: 430 rpm ■ Feed rate: 330 mm/min ■ Cutting depth: 30 mm ■ Cutting width: 12 mm ■ Material removal rate: 118 cc/min |
|----------------------------------------------------------------------------------------------------------------------------------------------------------------------------------------------------------------------------------------------------------------------------------|----------------------------------------------------------------------------------------------------------------------------------------------------------------------------------------------------------------------------------------------------------------------------------|



DRILLING

- | | |
|--------------------------------------------------------------------------------------------------------------------------------------------------------------------------|--------------------------------------------------------------------------------------------------------------------------------------------------------------------------|
| <ul style="list-style-type: none"> ■ Motor: 22/26kw / 4000rpm ■ Tool diameter: Ø75 mm ■ Speed: 750 rpm ■ Feed rate: 116 mm/min | <ul style="list-style-type: none"> ■ Motor: 22/26kw / 6000rpm ■ Tool diameter: Ø75 mm ■ Speed: 700 rpm ■ Feed rate: 105 mm/min |
|--------------------------------------------------------------------------------------------------------------------------------------------------------------------------|--------------------------------------------------------------------------------------------------------------------------------------------------------------------------|



TAPPING

- | | |
|-------------------------------------------------------------------------------------------------------------------------------------------------------------------------------------------------------|-------------------------------------------------------------------------------------------------------------------------------------------------------------------------------------------------------|
| <ul style="list-style-type: none"> ■ Motor: 22/26kw / 4000rpm ■ Tool diameter: M42 x 4.5 ■ Speed: 38 rpm ■ Feed rate: 171 mm/min ■ Motor load: 50% | <ul style="list-style-type: none"> ■ Motor: 22/26kw / 6000rpm ■ Tool diameter: M42 x 4.5 ■ Speed: 38 rpm ■ Feed rate: 171 mm/min ■ Motor load: 62% |
|-------------------------------------------------------------------------------------------------------------------------------------------------------------------------------------------------------|-------------------------------------------------------------------------------------------------------------------------------------------------------------------------------------------------------|

FULLY ENCLOSED SPLASH GUARD SAFETY, ELEGANCE



CENTRALIZED PNEUMATIC SYSTEM

All pneumatic parts are centralized, making the machine appearance neat and maintenance easy.



INDEPENDENT AIR ACCUMULATOR

The pneumatic system is equipped with a 150-liter large capacity air accumulator, which provides stable air supply to ensure motion stability of the air cylinders.

THREE BLOCKS ON EACH LINEAR WAY ON COLUMN

Each linear guideway on the column is equipped with three blocks, increasing the supporting force on each linear way. It also makes column movement more stable.

EXTENDED BLOCK

Each linear guideway is equipped with extended heavy-duty blocks for upgrading loading capacity and dynamic stability.



MODEL	Linear Ways & Blocks
HK-LH630(A)	X axis: 65 mm x 6 block Y axis: 55 mm x 6 block Z axis: 55 mm x 4 block
HK-LH800(A)	X,Y axis: 65 mm x 6 block Z axis: 65 mm x 4 block
HK-LH1000(A)	X,Y axis: 65 mm x 6 block Z axis: 65 mm x 4 block



AIR-COOLING THROUGH BALLSCREW (STANDARD) OIL-COOLING THROUGH BALLSCREW (OPTIONAL)

Cooling through ballscrew is available via two methods, dry air cooling (standard) and full oil cooling (optional) to ensure high machining accuracy.

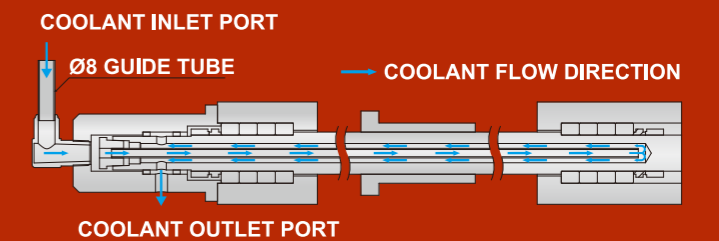

A CHIP FLUSH ON MACHINE TOP (OPTIONAL)

The machine top is equipped with several chip flushing nozzles. With the comprehensive chip flushing design, thermal deformation problems during machining can be fully avoided.

B SCISSORS TYPE TELESCOPIC GUARD

The X-axis is protected by scissors type telescopic guard with smooth motions.

※ Scissors type telescopic guards are used on X, Y, and Z-axes.

AUTOMATIC TOOL CHANGER



AUTOMATIC TOOL CHANGER

The cam type tool changer provides fast tool change. Fixed tool number and tool pocket position make it convenient to memorize the tool number and pick the tool.



FANUC CONTROLLER WITH SELF-DEVELOPED SOFTWARE

The Heake HK-LH horizontal machining center is equipped with a FANUC controller combined with the use of Heake self-developed software that dramatically upgrades convenience in machine operation and management.



40 TOOL CHAIN TYPE MAGAZINE (STANDARD)

- Tool loading capacity: 40 tools
- The tool magazine is driven by a hydraulic indexing motor for fast tool change and smooth motions.
- Bi-directional random tool selection

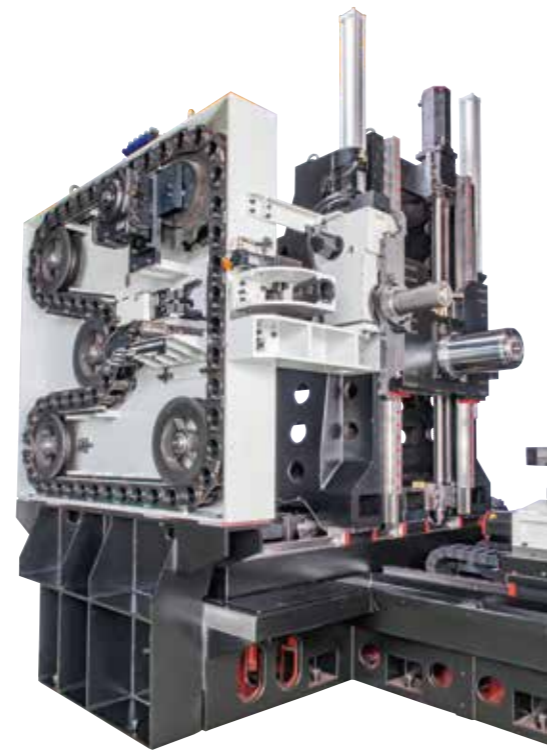

60 / 90 / 120 TOOL CHAIN TYPE MAGAZINE (OPTIONAL)

- Tool loading capacity: 60 tools
- The tool magazine is driven by a servomotor for fast positioning, smooth motions, and minimum trouble.
- Bi-directional random tool selection

INTELLIGENT FUNCTIONS



ATC Service Mode



Machine Apps



Peripheral Devices



Lube Information



APC Management



Utilization Rate



PLC Alarm List



Spindle Load Monitor



Tool List_40T



Tool Management



Workpiece Management

MACHINE SPECIFICATIONS

MODEL	UNIT	HK-LH-630(A)	HK-LH-800(A)	HK-LH-1000(A)
TABLE				
Table sizes	mm	630 x 630	800 x 800	1000 x 1000
Max. table load	kg	1200 x 2	2000 x 2	2000 x 2
Table height from floor	mm	1190	1300	1300
Max. workpiece sizes (dia. x height)	mm	Ø1100 x H1250	Ø1600 x H1450	Ø1650 x H1400
Least indexing degree on B-axis	deg	0.001°		
SPINDLE				
Spindle nose taper		7/24 Taper No. 50		
Max. spindle speed – direct drive / built in	rpm	8000 (10000)		
Max. spindle speed – gear drive		4000 / 6000		
TRAVEL				
Z, Y, Z-axis travel	mm	1000 x 900 x 1000	1500 x 1100 x 1100	1500 x 1100 x 1100
Dist. from spindle center to table surface	mm	50-950	50-1150	50-1150
Dist. from spindle nose to table surface		100-1100	250 (150)-1350 (1250)	250 (150)-1350 (1250)
FEED				
Rapid traverse rates on X, Y, Z-axis	mm/min	40 / 40 / 40	24 / 24 / 24 (30 / 30 / 30)	24 / 24 / 24 (30 / 30 / 30)
Cutting feed rate		1-20000		
ATC				
Tool shank type	pc	BT-50 (BBT-50)	BT-50 (BBT-50)	BT-50 (BBT-50)
Tool loading capacity	mm	40(60)(90)(120)		
Max. tool diameter	mm	Ø125		
Max. tool diameter (without adjacent tool)	mm	Ø250 (Ø450)		
Max. tool length	kg	550		
Max. tool weight		25		
MOTOR				
Spindle motor	kW	15/ 18.5 (18.5/22)(22/26)		
Servomotors on X, Y, Z-axis		7 / 7 / 7	6 / 6 / 6	6 / 6 / 6
MACHINE DIMENSIONS				
Width x depth x height	kg	4930 x 7510 x 3690	5465 x 7930 x 3960	5465 x 7930 x 3960
Weight (with single pallet)		16900	21800	26800
Weight (with twin pallets)		20800	25200	30200
CONTROLLER				
Fanuc Oi-MF Plus / 31i-MB				

*As the machine manufacturer constantly conducts machine research and improvement, the machine specifications are subject to change without prior notice.

MACHINE DIMENSIONS

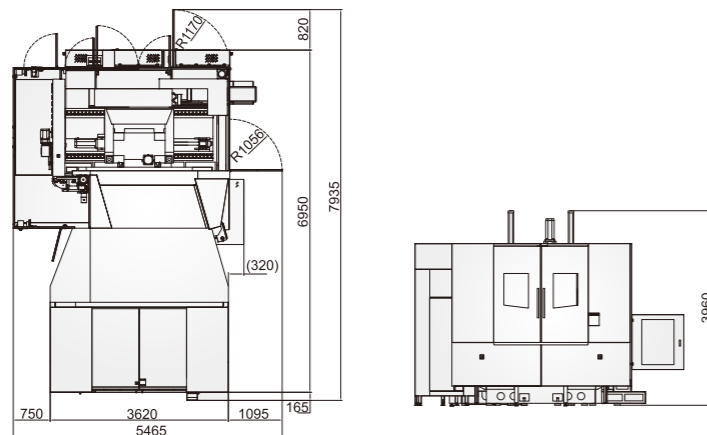

HK-LH-800(A) / 1000(A)

STANDARD / OPTIONAL EQUIPMENT

		STANDARD	OPTIONAL
SPINDLE	4000 / 6000 rpm large torque spindle	●	
	10000 rpm built-in type spindle		●
	10000 rpm direct-drive spindle		●
B-AXIS	0.001° Indexing table (B-axis encoder is optional)	●	
	1° Indexing table		●
TOOL SHANK	BT50	●	
	HSK-A100		●
	DIN50		●
	CAT50		●
DEGREE OF BT50 PULL STUD	MAS407 BTI (45°)	●	
	MAS407 BTII (60°)		●
	MAS407 BTIII (90°)		●
PUMP OF COOLANT THROUGH MACHINE	20 bar		●
	40 bar		●
	70bar		●
MAGAZINE LOADING CAPACITY	40pc	●	
	60pc		●
	90pc		●
	120pc		●
COOLING SYSTEM	Spindle cooling system	●	
	Air conditioner for electric cabinet	●	
	Hydraulic oil temperature control system		●
	Cutting fluid temperature control system		●
AUTO PALLET CHANGE	Single table	●	
	Twin tables		●
	PPL system		●
CHIP REMOVAL IN MACHINE	Twin chip augers	●	
	Chain type chip conveyor	●	
CHIP CONVEYOR	Magnetic scraper type chip conveyor		●
	Scraper type chip conveyor		●
	Roller type chip conveyor		●
	Integrated type chip conveyor		●
	General lubrication oil system	●	
LUBRICATION OIL SYSTEM	LHL grease lubrication system (grease)		●
	5 μm class		●
3 AXES LINEAR SCALES	3 μm class		●
	Overarm supply 6 ports at each side (max. hyd. pressure 120 bar). Oil inlet through patio.		●
JIG LUB. / COMP. AIR SUPPLY	Table type 6 oil ports on APC (max. hyd. pressure 120 bar). Oil inlet through bottom.		●
	Tool breakage detection (mounted at the magazine side for detecting)		●
TOOL MEASURING SYSTEM	Renishaw TW-27R retract contact type sensor (mounted in the machine, the device is suitable for detecting tool length, tool breakage, and tool diameter).		●
	FANUC Oi-MF Plus	●	
CONTROLLER	FANUC 31i-MB		●
	Air gun	●	
OTHER EQUIPMENT	Coolant gun	●	
	Oil fluid separator	●	
	OMP60 / RMP60 workpiece measuring system		●
	Air blast for machining		●
	Oil mist collector		●